



KAT5.tv AV Distribution System

KAT5 AVTX User Guide



KAT5 AVTX

Mk2 AV Transmitter

User Guide

Version 1.0
1st August 2005

Overview

The KAT5 AVTX is a device that connects to the AV output of an item of Consumer Electronics e.g. Sky Receiver, Video Recorder, DVD Player etc and electronically balances the signals for transmission over a CAT5 Structured Cabling system.

Used with the appropriate KAT5 Receiver, this allows high quality Audio and Video signals to be distributed over low cost cabling. The quality of the display on the receiving display is that same as would be obtained if the source device were located near the display.

The KAT5 AVTX can be used for the following signal types

- S-Video + Stereo Audio
- 2 Composite Video Signals + 2 Mono Audio signals
- Composite Video + SPDIF Digital Audio + Stereo Audio

The KAT5 AVTX allows Infra Red control signals to be relayed to the source equipment and also extends the SCART switching signals to the receiving display.

KAT5 Infra Red is based on a 38kHz Carrier Frequency. The vast majority of Consumer AV Equipment uses remote control frequencies in the range 36kHz to 40kHz and should work with no problems whatsoever. KAT5 Infra Red WILL NOT work with remote controls that use 455kHz or IRDA

System Requirements

In order to use the KAT5 AVTX you will need either a Structured Cabling scheme or a dedicated CAT5 Cable. You will also require a suitable KAT5 receiver at the distant end.

Structured Cabling Scheme

A structured cabling scheme consists of RJ45 outlets (typically 2 or 4 per faceplate) in convenient locations around the building. Each of these are individually numbered and wired back to a Patch Panel using CAT5 cable where different services may be connected to them.

Dedicated Cable

A dedicated CAT5 cable is run between the location of the source equipment and the location of the display. Wherever possible you should consider installing a structured wiring scheme as this allows much more flexibility for future changes.



Installation

SCART Socket

Connect the source equipment to the AVRX SCART socket.

If your display does not have a SCART socket you may need to use a suitable adapter.

Connection details are shown below.

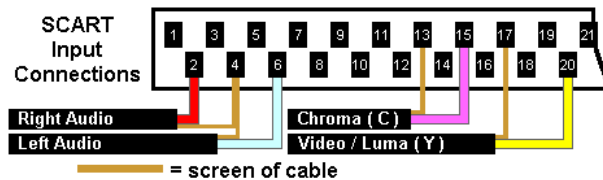

Power Supply Input

The KAT5 AVTX requires a Regulated 12V DC Power supply capable of supplying at least 150mA. The power connector is a 2.1mm DC Power Plug centre positive. The Yellow Power LED will illuminate to indicate that the supply is active.

2.1mm DC Power Plug



3.5mm IR Emitter Jack



InfraRed Emitter

In order to control the source equipment an InfraRed Emitter is required. The emitter supplied with KAT5 units is a stick on emitter that attaches to the IR Window on the source equipment. This connects to the 3.5mm Jack Socket.

The emitter is fitted with a "Blink LED" which flashes when active allowing visual feedback that signals are being sent to the equipment. Depending on the format of the IR signals used this may appear to be very dim and of short duration. This is not a fault.



Some experimentation may be required to find the best position for the IR Emitter.

CAT5 Cable Connection

The KAT5 AVRX should be connected to the distant KAT5 Transmitter using a fully wired CAT5 cable.



All patch cables should be straight wired not crossover.

PLEASE NOTE: The KAT5 AV Distribution System uses the physical medium of CAT5 cable to carry the audio and video signals. KAT5 is **NOT** an Ethernet based product and should not be connected to Ethernet Hubs/Switches/Routers. Doing so may result in damage to your equipment.



KAT5.tv AV Distribution System

KAT5 AVTX User Guide

Termination Switches

If the source equipment is to be connected to several KAT5 units or a KAT5 Unit and a Local TV, it is necessary to remove the termination from the input of the KAT5 AVTX as video signals must only be terminated once. The case of the KAT5 unit can be opened by removing the two Pozidrive screws located on the bottom of the case.

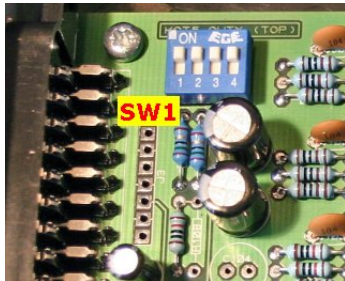

Adjacent to the SCART socket is a bank of 4 switches.

These are normally set to ON.
Move the switches to the OFF position to disable the termination.

Switch assignment is as follows		Default Setting
• SW1.1	S-Video Chroma	ON
• SW1.2	S-Video Luma or Composite Video	ON
• SW1.3	Left Audio	ON
• SW1.4	Right Audio	ON

Typical Setup

The diagram below shows a typical setup for a KAT5 Transmitter. This diagram should be used when the AVTX is the only device connected to the source equipment, or when the source equipment has multiple outputs as is the case with many DVD Players and Set Top boxes.

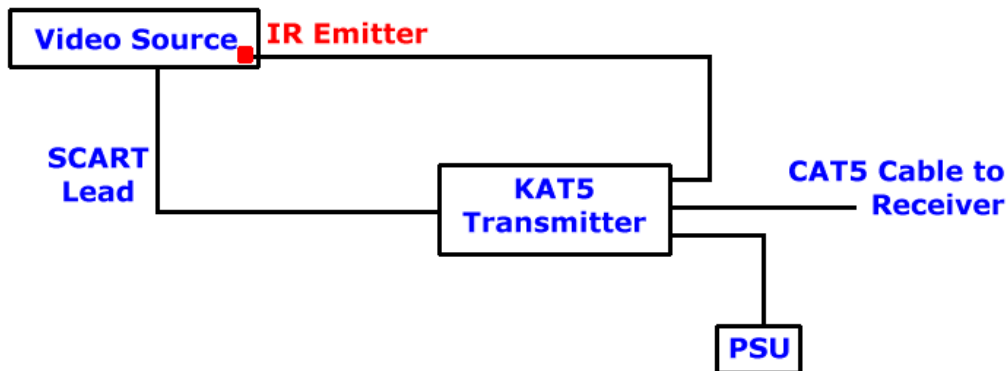

Multiple Device Setup

If the source equipment is to be connected to other equipment in addition to the KAT5 Transmitter the diagram below should be used as an example.

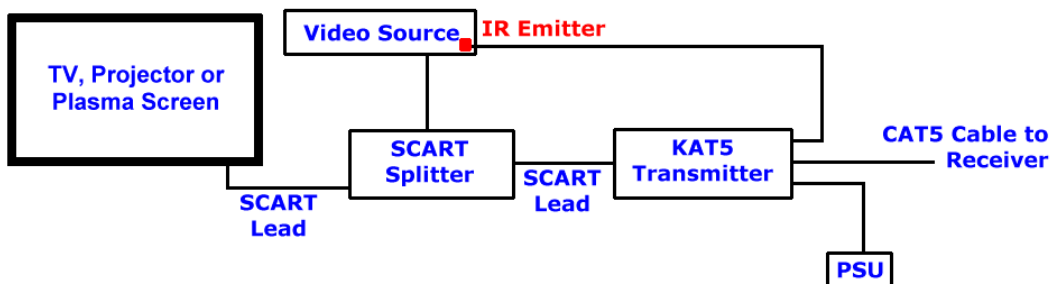

Normally a distribution amplifier would be required for multiple devices but because the KAT5 AVTX has switchable input termination a simple passive SCART splitter block can be used. In this case the termination switches in the AVTX should be set to OFF.



Common Problems

This section covers basic fault finding for a KAT5 installation. More detailed fault finding information can be found at <http://www.kat5.tv/troubleshooting.html>

Loss of one audio or video channel. This is almost always a cabling fault. KAT5 uses all eight wires in a CAT5 cable and a broken termination or reversed pair will cause a channel to stop working. Ensure that the CAT5 patch cords are fully wired and not crossover cables.

Picture is Black and White. There are several possible causes for this problem.

1. The source and display are expecting different formats of video signal.
Eg Source is set to S-Video, display is set to Composite Video.
2. Either the source or display does not support S-Video via SCART. In this case you will need to use a SCART Adapter and MiniDin + Phono Leads.
3. Video format switches incorrectly set in AVRX. Refer to the table for correct settings.
4. Fault on the Brown/White pair between the Transmitter and Receiver.

Picture is bright and colours appear washed out. This indicates that the video levels are incorrect and is caused by incorrect termination. Check the termination switches in the AVTX and AVRX are correctly set for the way your system is configured.

Picture is dark and may be unstable. This indicates that the video levels are incorrect and is caused by multiple terminations. If you have a Multidrop installation, ensure that the termination is disabled in all the intermediate receivers (SW2 1-4 and SW3 1-4). If the transmitter is being fed from a SCART splitter block ensure that the terminations (SW1 1-4) in the AVTX are turned OFF.

Infra Red Repeater not working. The feedback LEDs on the IR Receiver and IR Emitter should indicate whether a signal is being received and retransmitted. Check that the termination switches in the AVRX are turned ON (SW2 1-4 and SW3 1-4). The IR Emitter may not be in the optimum position on the source equipment. IR functionality is not available for intermediate receivers.

Buzzing or picture disturbance when IR is relayed. Ensure that ALL eight switches of SW2 and SW3 in the AVRX are ON. This can also be caused by a faulty CAT5 cable.

KAT5 Support

KAT5 support is available from several sources.

Email support@kat5.tv with details of your problem or use the discussion forums.

<http://www.automatedhome.co.uk/modules.php?name=Forums&file=viewforum&f=19> is a web based forum hosted by AutomatedHome.co.uk

<http://groups.yahoo.com/group/kat5-users/> is an email based forum hosted on Yahoo Groups



Designed and manufactured in the UK

© 2001 – 2005 KAT5.tv

The latest version of this document can be found at <http://www.kat5.tv/docs/avtx.pdf>

End of document